

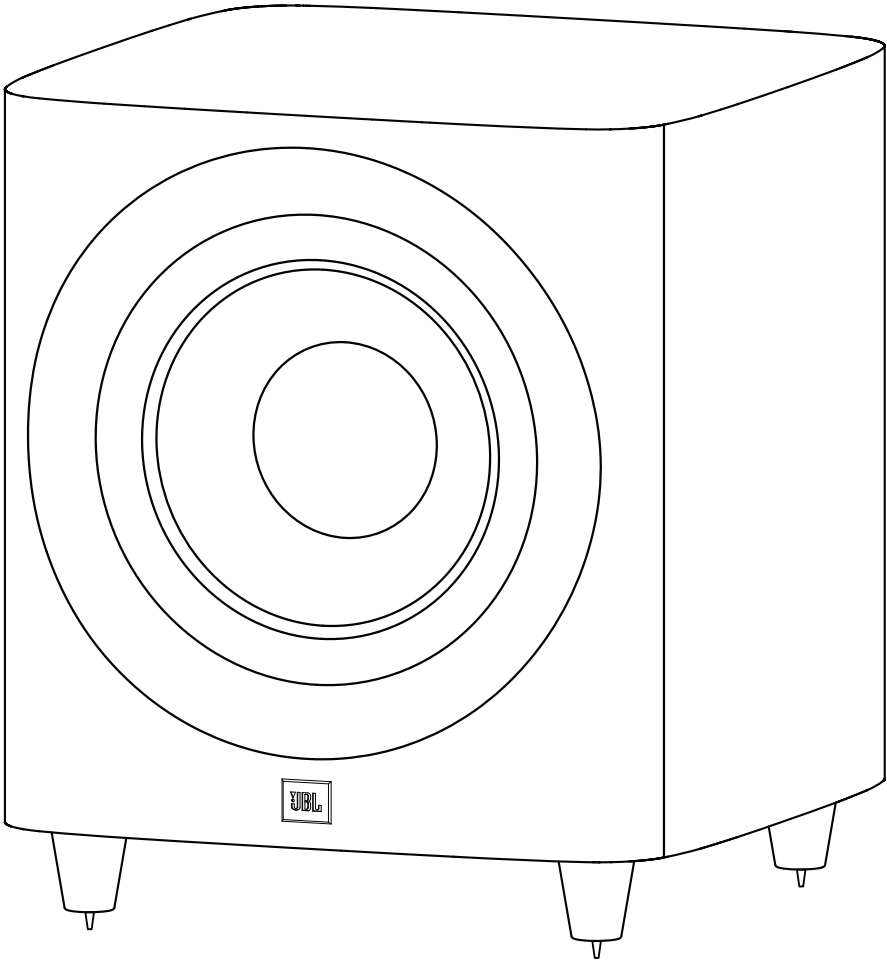



HDI-1200P

Powered Subwoofer



OWNER'S MANUAL

IMPORTANT SAFETY INSTRUCTIONS

1. Do not install this equipment in a confined or building-in space such as a book case or similar unit, and remain a well ventilation conditions at open site.
The ventilation should not be impeded by covering the ventilation openings with items such as newspaper, table-cloths, curtains etc.
2. No naked flame sources, such as lighted candles, should be placed on the apparatus.
3. The product is designed to use in moderate climates
4. Voltage selector: Used to adjust the input rating (110-120 Vac/60 Hz and 220-240 Vac/50 Hz), please just insert the mains power plug into the socket-outlet with voltage within the setting of the selector. The current ratings of mains fuse links are different for different input rating (see marking for details), and the fitted mains fuse link was just related to the input rating as setting of the selector during factory assembly line work, **please ask a qualified personnel to help you replace the mains fuse link before you adjust the voltage selector.**
5.  Protective earthing terminal. The apparatus should be connected to a mains socket outlet with a protective earthing connection.
In Denmark: "Apparatets stikprop skal tilsluttes en stikkontakt med jord, som giver forbindelse til stikproppens jord."
In Finland: "Laite on liitettävä suojakoskettimilla varustettuun pistorasiaan"
In Norway: "Apparatet må tilkoples jordet stikkontakt"
In Sweden: "Apparaten skall anslutas till jordat uttag"

WARNING

1. Only use attachments/accessories specified or provided by the manufacturer.
2. To reduce the risk of fire or electric shock, do not expose this apparatus to rain or moisture.
The apparatus shall not be exposed to dripping or splashing and that objects filled with liquids, such as vases, shall not be placed on apparatus.
3. The mains plug is used as disconnect device, the disconnect device shall remain readily operable.

TABLE OF CONTENTS

INCLUDED ITEMS	1
ATTACHING THE GRILLE	2
SUBWOOFER REAR-PANEL CONTROLS AND CONNECTION	3
CONNECTING THE SUBWOOFER TO A TRIGGER VOLTAGE SOURCE	4
PLACING THE SUBWOOFER	5
MAKING CONNECTIONS	5
CONNECTING TO A STEREO RECEIVER, AMPLIFIER OR PREAMPLIFIER	6
SPECIFICATIONS	7
OPERATING THE SUBWOOFER	7
TURNING THE SUBWOOFER ON AND OFF.....	7
SUBWOOFER ADJUSTMENTS: CROSSOVER	7
SUBWOOFER ADJUSTMENTS: VOLUME	7
SUBWOOFER ADJUSTMENTS: PHASE.....	7
ABNORMAL CONDITION: LED flashing.....	7
USING THE SUPPLIED CARPET SPIKES.....	7



HDI-1200P

Powered Subwoofer

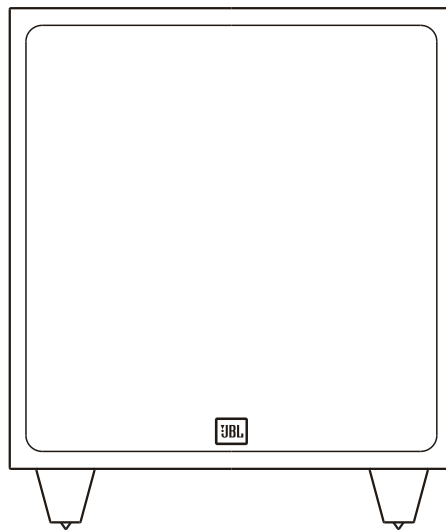

THANK YOU FOR CHOOSING THIS JBL® PRODUCT

Your new JBL® powered subwoofer incorporates a high-performance transducer and built-in amplifier that delivers the powerful, dynamic and accurate low-frequency performance that makes your film soundtracks and music come alive. And with adjustable crossover, phase controls and automatic turn on/off, it is also simple to connect and set up.

We're confident that this JBL subwoofer will provide every note of enjoyment that you expect – and that when you think about purchasing additional audio equipment for your home, car or office, you will once again choose JBL products.

This quick-start guide contains all the information you need to set up, connect and adjust your new subwoofer. For more in-depth information, go to our web site: www.jblsynthesis.com.

INCLUDED ITEMS

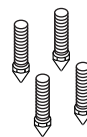
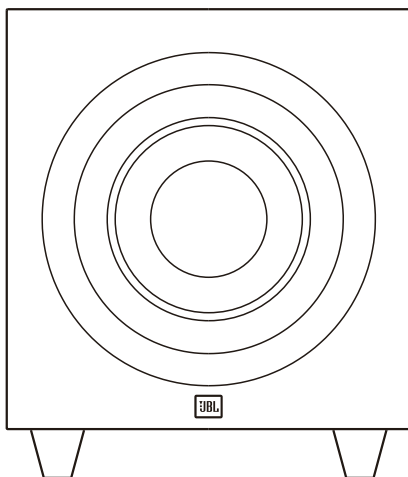

4X

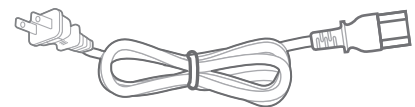

1X

Note: Type of power plug varies by regions.

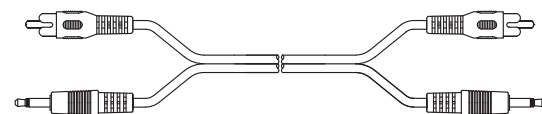

1X

One combination LFE and trigger cable

ATTACHING THE GRILLE

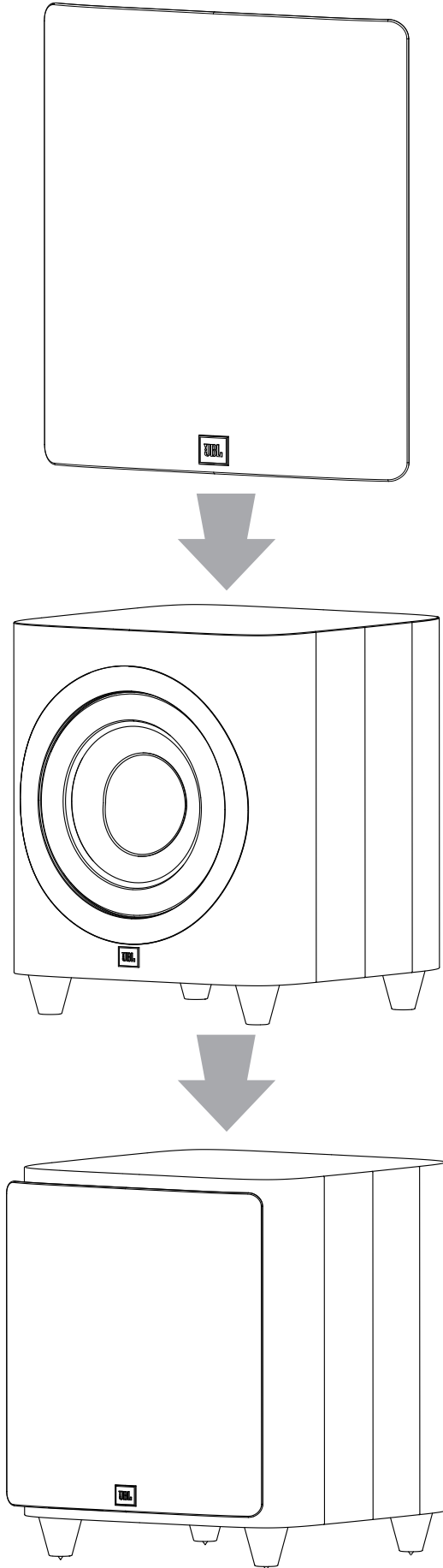

SUBWOOFER REAR-PANEL CONTROLS AND CONNECTION

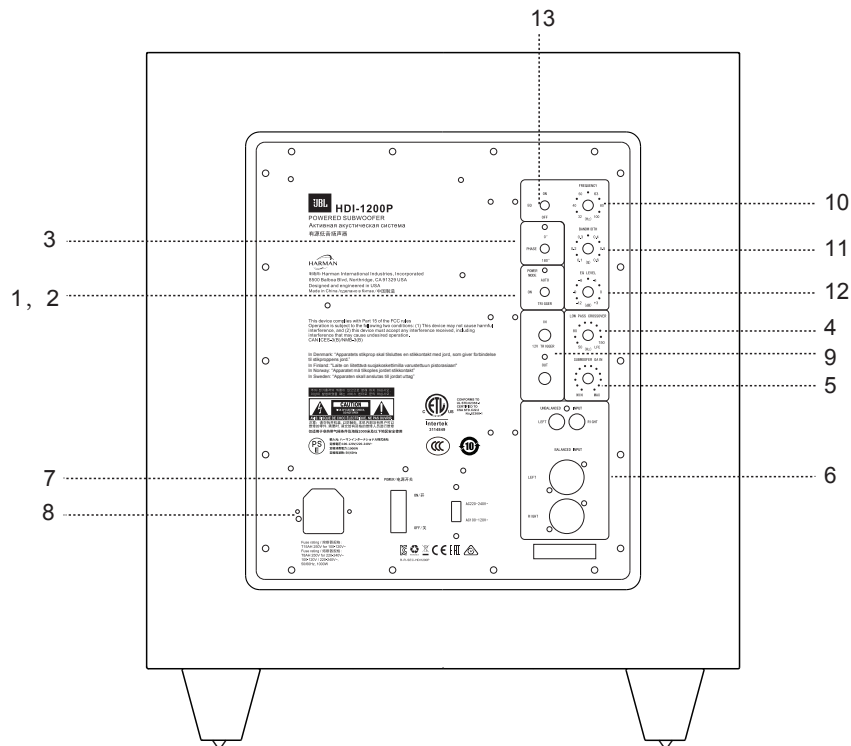

1) Power Mode:

When switched to 'Auto' position, the subwoofer will then be in Standby mode. It will automatically turn on when an audio signal is detected and will return to the Standby mode when no audio signal is detected after approximately 10 minutes. Setting this switch to 'On' keeps the subwoofer powered until Power Switch is turned 'Off.'

2) On/Standby LED:

When the Power Switch is in the 'On' position, this LED indicates whether the subwoofer is in the On or Standby state.

- When the LED glows *green*, the subwoofer is turned On.
- When the LED glows *red*, the subwoofer is in the Standby mode.

3) Phase Switch:

This switch determines whether the subwoofer transducer's piston-like action moves in and out in phase with the main speakers. If the subwoofer were to play out of phase with the main speakers, the sound waves from the main speakers could partially cancel out the sound waves from the subwoofer, reducing bass performance and sonic impact. This phenomenon depends in part on the placement of all the speakers relative to the listening position and to each other in the room.

4) Low Pass Crossover:

This control determines the highest frequency at which the subwoofer reproduces sounds. The higher you set the Crossover control, the higher in frequency the subwoofer will operate and the more its bass will "overlap" that of the speakers. This adjustment helps achieve a smooth transition of bass frequencies between the subwoofer and the speakers for a variety of different rooms and subwoofer locations.

5) Subwoofer Gain:

Use this control to adjust the subwoofer's volume. Turn the knob clockwise to increase the volume; turn the knob counterclockwise to decrease the volume.

6) Input Connectors:

Connect these to the outputs of a stereo preamp or connect a surround processor's subwoofer output to either the left or right input. Balanced (XLR) and unbalanced (RCA) connectors are available. The inputs are 0dBV nominal to +12dBV max unbal/+18dBV max bal. The XLR input is pin 2 hot.

7) Power Switch:

Set this switch in the 'On' position to turn the subwoofer on. If you will

be away from home, or will not be using the subwoofer for an extended period, set this switch in the 'Off' position to conserve energy.

8) Power Cord Connector:

After you have made and verified the subwoofer's input connection, plug the power cord into an active, unswitched electrical outlet for proper operation of the subwoofer.

DO NOT plug the power cord into the accessory outlets found on some audio components.

9) 12V Trigger In/Out connectors:

When the subwoofer's Power Mode Switch is set to "Trigger", the subwoofer will automatically turn on when 5V-12V is present at the 12V Trigger "in-connection", and will turn off when the voltage at this connection is removed. Whenever the subwoofer is on, a 12V trigger signal is available at its 12V Trigger Out connector. It is for use with additional HDI-1200P subwoofers, or another triggerable device.

10) Parametric Equalization (PEQ) controls:

This set of equalization controls adjust for the dominant room mode at your listening position in your specific listening room. The parametric equalizer includes variable controls to adjust Frequency, Bandwidth, and EQ Level of one band of frequencies. To use these controls, you must first set the EQ switch to "ON".

NOTE: Specific measurement equipment is required to properly adjust the Equalization controls. Your authorized JBL dealer can make the appropriate measurements, using suitable equipment to ensure optimal results.

11) EQ Frequency control:

Selects the center frequency of the particular problem area. The range is from 32Hz to 100Hz.

12) EQ Bandwidth control:

Sets the range of frequencies over which the equalizer will have an effect. The range is from 0.1 octaves to 0.6 octaves; the higher the number the broader the range of frequencies that will be affected.

13) EQ Level control:

Allows you to adjust how much boost or cut is applied to the selected frequency by the EQ Frequency Control. This control adjusts from -12dB to a maximum of +3dB.

14) EQ On/Off switch:

Enables/Disables the parametric EQ controls (Frequency, Bandwidth, and EQ Level, but not Phase)

CONNECTING THE SUBWOOFER TO A TRIGGER VOLTAGE SOURCE

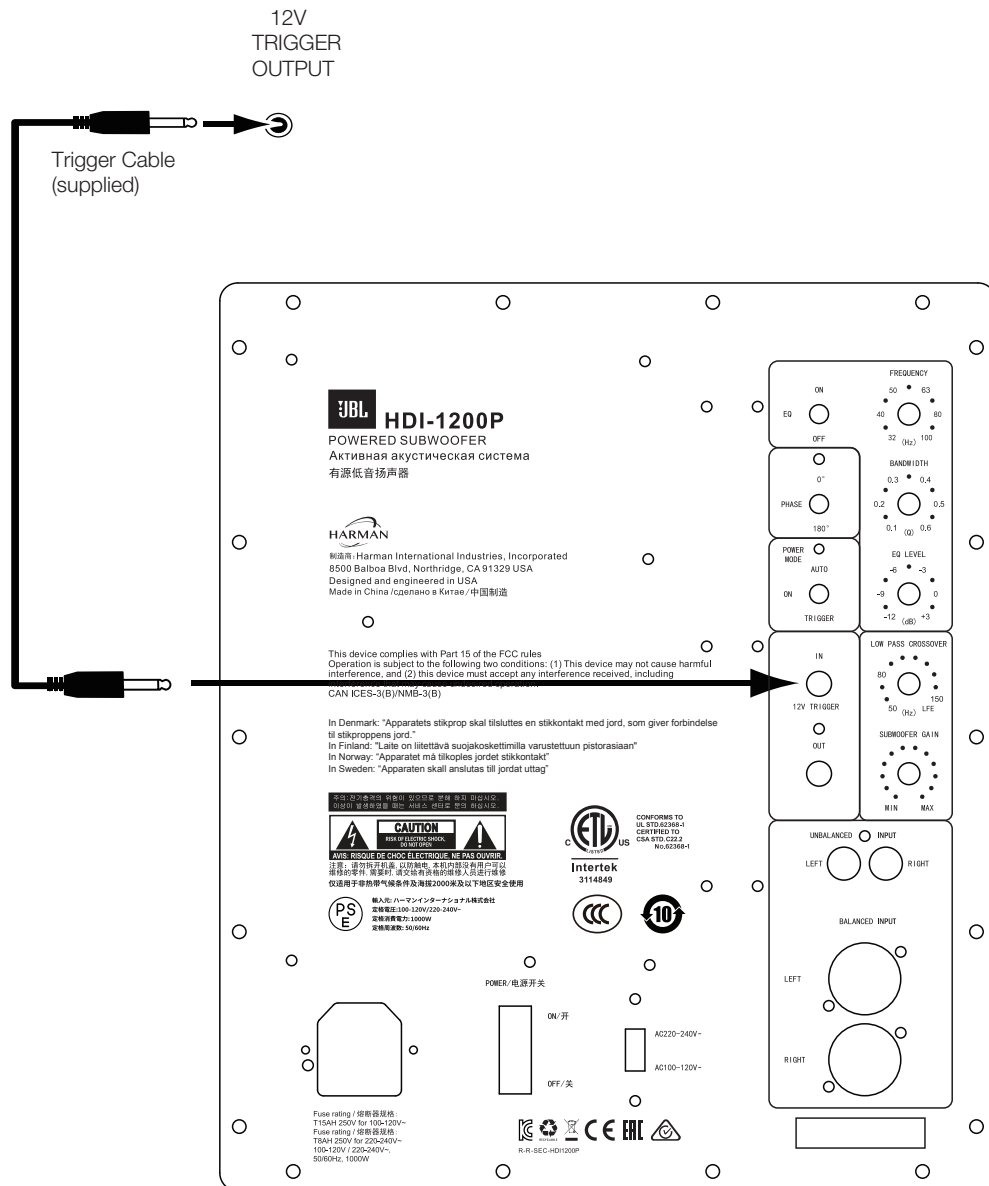

The subwoofer will automatically turn on if it receives a trigger voltage at its External Trigger Input connector and will enter the Standby mode when the voltage ceases.

If your preamp/processor or another audio/video component has a trigger-voltage connection that supplies between 3V and 30V (AC or DC), connect it to subwoofer's External Trigger Input connector. If the component's trigger-voltage connection has a 3.5mm mini jack, you can use the supplied combination LFE/trigger cable to make the connection.

NOTE: Do not connect the subwoofer's External Trigger input connector to a remote control output (IR Out) of your home cinema system or surround receiver. Doing so could lead to malfunction.

PLACING THE SUBWOOFER

The performance of a subwoofer is directly related to its placement in the listening room and its physical position relative to the other speakers in the system.

While it is true that in general our ears do not hear directional sounds at the low frequencies where subwoofers operate, when installing a subwoofer within the limited confines of a room, the reflections, standing waves and absorptions generated within the room will strongly influence the performance of any subwoofer system. As a result, the specific location of the subwoofer in the room does become important to the amount and quality of bass that is produced.

For example, placing the subwoofer next to a wall generally will increase the amount of bass in the room; placing it in a corner (1) generally will maximize amount of bass in the room. However, corner placement can also increase the destructive effect of standing waves on bass performance. This effect can vary depending on the listening position – some listening positions may yield very good results while others may have far too much (or too little) bass at certain frequencies.

In many rooms, placing the subwoofer along the same plane as the left and right speakers (2) can produce the best integration between the sound of the subwoofer and that of the left and right speakers. In some rooms, the best performance could even result from placing the subwoofer behind the listening position (3).

We strongly recommend that you experiment with placement before choosing a final location for your subwoofer. One way you can determine the best location for the subwoofer is by temporarily placing it in the listening position and playing music with strong bass content. Move around to various locations in the room while the system is playing (putting your ears where the subwoofer would be placed), and listen until you find the location where the bass performance is best. Place the subwoofer in that location.

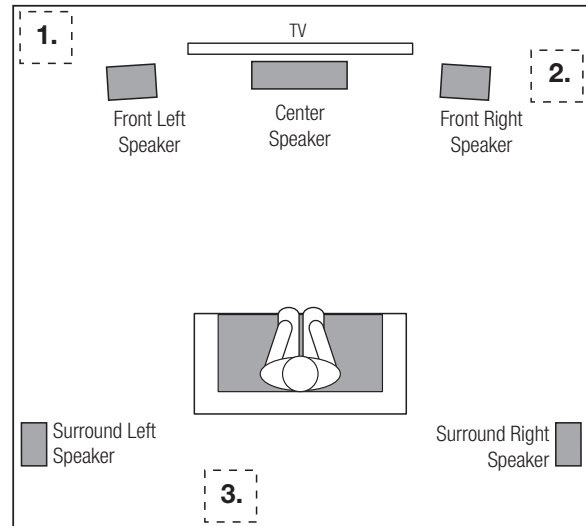

MAKING CONNECTIONS

CAUTION: Never make or break connections unless all system components are powered off.

CONNECTING TO AN AV SURROUND RECEIVER OR PROCESSOR WITH AN INTERNAL CROSSOVER

If you are connecting to a surround processor with a low-pass filtered subwoofer output, connect the subwoofer as shown below. You can make either a balanced (XLR) or unbalanced (RCA) connection to either the subwoofer's left or right input connector. **When connecting to surround processors with internal crossovers, set the Low Pass crossover control knob to the "LFE" position.**

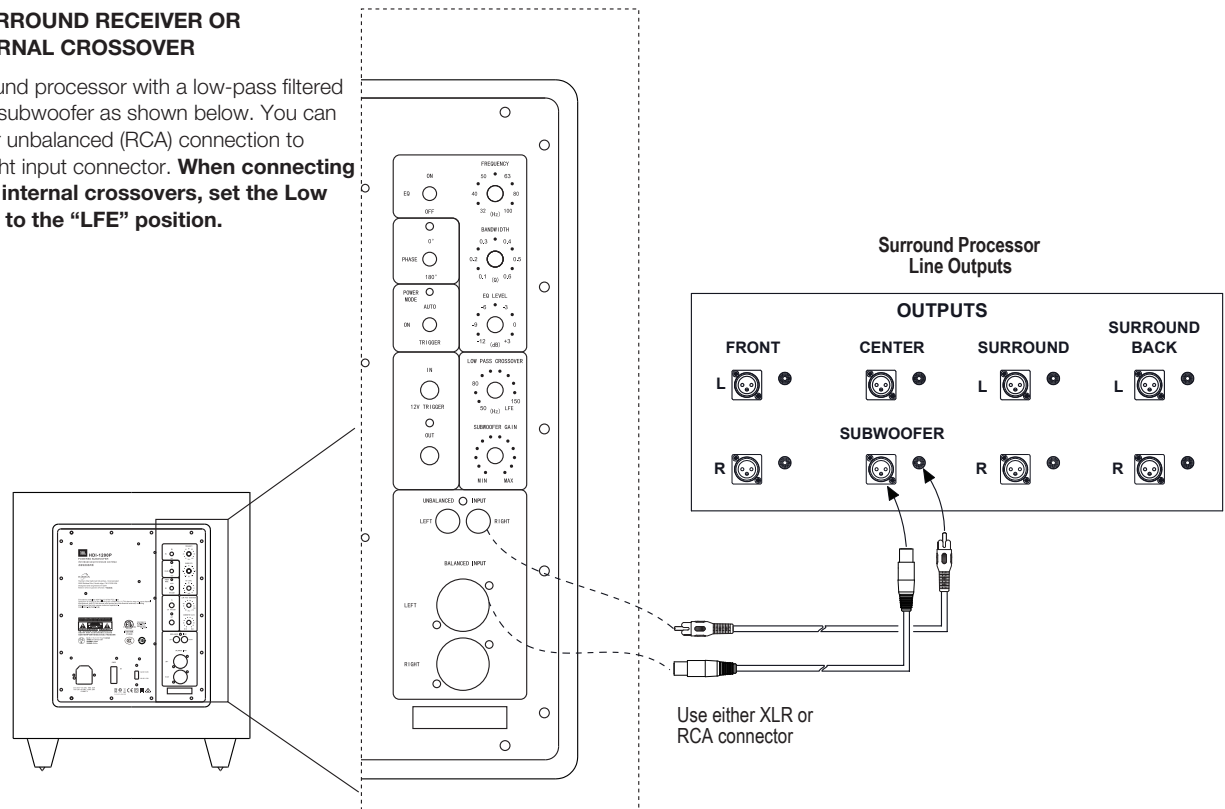

CONNECTING TO A STEREO RECEIVER, AMPLIFIER OR PREAMPLIFIER

If you are connecting to a stereo device, connect the subwoofer as shown below. Stereo components rarely have subwoofer outputs. Use them if they are available; otherwise, be sure to use a Y-connector for the left output and one for the right output, connecting the subwoofer input to one side of each Y and the input for the left or right or right main speaker amplifier to the other side of the Y for proper main speaker operation. You can make either balanced (XLR) or unbalanced (RCA) connections between the device and the subwoofer.

Using this connection method, you must set the Low Pass Crossover knob to some frequency between 50-150Hz, NOT on the “LFE” setting.

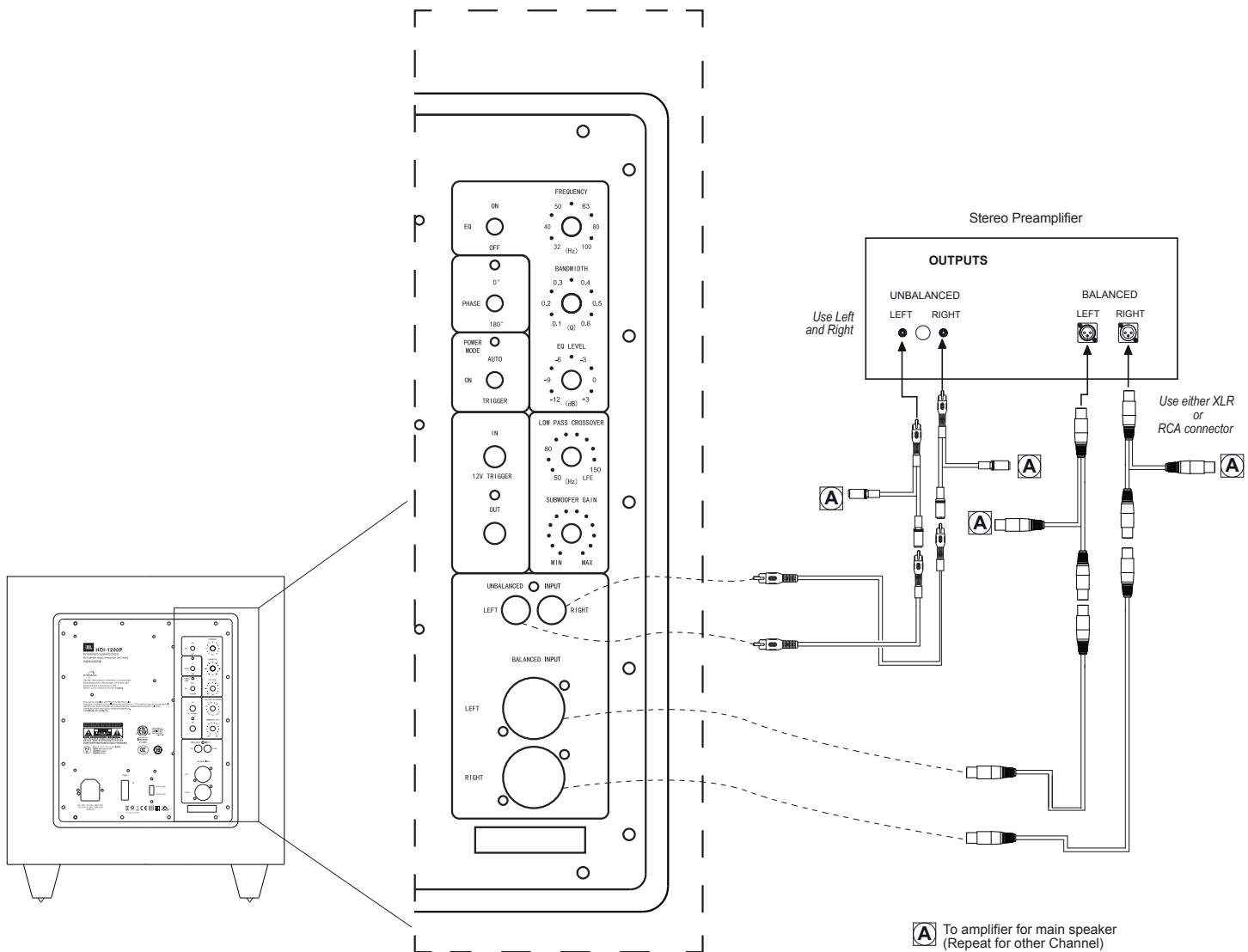

SPECIFICATIONS

MODEL	HDI-1200P
DESCRIPTION	1000W RMS Powered Subwoofer
ENCLOSURE TYPE	Bass-reflex design with down-firing ports
LF DRIVER COMPONENTS	12-inch / 300mm black paper cone, cast-frame woofers
CROSSOVER FREQUENCY	50Hz – 150Hz (variable) 24dB/octave
FREQUENCY RESPONSE	28Hz - 150Hz(-6dB)

POWER REQUIREMENT	100V - 240V 50/60Hz
POWER CONSUMPTION (Idle/Max)	<0.5W (standby) 1180W/7.7A(max-230Vac) 1230W/12.87A(max-120Vac) 1190W/15.97A(max-100Vac)
Dimensions (W x D x H, grille included):	16.3" x 17.77" x 16.95" (414 x 451.3 x 430.5mm)
Product Weight (grille included):	70.08lb (31.79kg)

OPERATING THE SUBWOOFER

TURNING THE SUBWOOFER ON AND OFF

Set the subwoofer's Power Switch to the 'On' position. Now set the subwoofer's Power Mode to the 'Auto' position. The subwoofer will automatically turn itself on when it receives an audio signal, and it will go into Standby mode after it has received no audio signal for approximately 10 minutes. The subwoofer's LED will glow *green* when the subwoofer is on and will glow *red* when the subwoofer is in Standby.

If you will not be using the subwoofer for an extended period – for instance, if you're going on vacation – set the Power Switch to the 'Off' position.

SUBWOOFER ADJUSTMENTS: CROSSOVER

The Crossover control adjusts the subwoofer's built-in low-pass filter crossover between 50Hz and 150Hz. The higher you set the Crossover control, the higher in frequency the subwoofer will operate and the more its bass will 'overlap' that of the speakers. This adjustment helps achieve a smooth transition of bass frequencies between the subwoofer and the speakers for a variety of different rooms and subwoofer locations.

To set the Crossover control, listen for the smoothness of the bass. If the bass seems too strong at certain frequencies, try a lower Crossover control setting. If the bass seems too weak at certain frequencies, try a higher Crossover control setting.

SUBWOOFER ADJUSTMENTS: VOLUME

Use the volume control to set the subwoofer's volume. Turn the knob clockwise to increase the subwoofer's volume; turn the knob counterclockwise to decrease the volume. Once you have balanced the subwoofer's volume with that of the other speakers in your system, you shouldn't have to change the volume control setting.

Notes on Setting Subwoofer Volume:

- Sometimes the ideal subwoofer volume setting for music is too loud for films, while the ideal setting for films is too quiet for music. When setting the subwoofer volume, listen to both music and films with strong bass content and find a 'middle ground' volume level that works for both.
- If your subwoofer always seems too loud or too quiet, you may want to place it in a different location. Placing the subwoofer in a corner will tend to increase its bass output, while placing it away from any walls or corners will tend to lessen its bass output.

SUBWOOFER ADJUSTMENTS: PHASE

The Phase switch determines whether the subwoofer driver's piston-like action moves in and out in phase with the speakers. If the subwoofer were to play out of phase with the speakers, the sound waves from the speakers could partially cancel out the waves from the subwoofer, reducing bass performance and sonic impact. This phenomenon depends in part on the placement of all the speakers relative to each other and the listener(s) in the room.

Although in most cases you should leave the Phase switch in the 'Normal' position, there is no absolutely correct setting for the Phase switch. When the subwoofer is properly in phase with the speakers, the sound will be clearer and have maximum impact, and percussive sounds like drums, piano and plucked strings will sound more life-like. The best way to set the Phase switch is to listen to music that you know well and to set the switch in the position that gives drums and other percussive sounds maximum impact.

ABNORMAL CONDITION: LED flashing

- LED flashing in *red* <30sec: Subwoofer is in protection mode and will recover. LED becomes *green* color.
- LED flashing in *red* >30sec: Unplug/switch-off AC power till LED light off. Plug-in/switch-on AC power and subwoofer will recover. LED becomes *green* color.

USING THE SUPPLIED CARPET SPIKES

Four metal spikes are supplied for use when you place the subwoofer on a carpeted surface. Do not use these spikes when placing subwoofer on non-carpeted surfaces.

To insert the spikes:

1. Gently lay the subwoofer on its side (not its front or back) on a soft, nonabrasive surface.
2. Screw each spike into the threaded insert in each foot. Make sure all four spikes are screwed in completely for stability.

Note: NEVER drag the subwoofer to move it. Always carefully lift the subwoofer and carry it to its new location.

Торговая марка	: JBL
Назначение товара	: Активная акустическая система (HDI-1200P)
Изготовитель	: Харман Интернешнл Индастриз Инкорпорейтед, США, 06901 Коннектикут, г.Стэмфорд, Атлантик Стрит 400, офис 1500
Страна происхождения	: Китай
Импортер в Россию	: ООО «ХАРМАН РУС СиАйЭс», Россия, 127018, г.Москва, ул. Двинцев, д.12, к 1
Гарантийный период	: 1 год
Информация о сервисных центрах	: www.harman.com/ru тел. +7-800-700-0467
Срок службы	: 5 лет
товар сертифицирован	: 
Дата производства	: Дата изготовления устройства определяется по двум буквенным обозначениям из второй группы символов серийного номера изделия, следующих после разделительного знака «-». Кодировка соответствует порядку букв латинского алфавита, начиная с января 2010 года: 000000-MY0000000, где «M» - месяц производства (A - январь, B - февраль, C - март и т.д.) и «Y» - год производства (A - 2010, B - 2011, C - 2012 и т.д.).

Используйте устройство только по прямому назначению в соответствии с предоставленной инструкцией. Не пытайтесь самостоятельно вскрывать корпус товара и осуществлять ремонт. В случае обнаружения недостатков или дефектов, обращайтесь за гарантийным обслуживанием в соответствии с информацией из гарантийного талона. Особые условия хранения, реализации и (или) транспортировки не предусмотрены. Избегайте воздействия экстремальных температур, длительного воздействия влаги, сильных магнитных полей. Устройство предназначено для работы в жилых зонах. Срок годности не ограничен при соблюдении условий хранения.

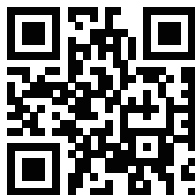

EN :For additional languages, please visit jblsynthesis.com
FR :Pour les autres langues, veuillez visiter jblsynthesis.com
ES :Para obtener otros idiomas, visite jblsynthesis.com
DE :Informationen in weiteren Sprachen finden Sie unter jblsynthesis.com
RU :Если вам нужны версии на других языках, перейдите на сайт jblsynthesis.com
JP :他の言語で読むには、jblsynthesis.com にアクセスしてください
KO :추가 언어에 대해서는 jblsynthesis.com 에서 확인하십시오
CHN:如需其他语言, 请访问 www.jblsynthesis.com





产品中有害物质的名称及含量

部件名称	目标部件	有害物质或元素					
		铅(Pb)	汞(Hg)	镉(Cd)	六价铬(Cr(VI))	多溴联苯(PBB)	多溴二苯醚(PBDE)
电路板	印刷电路板, 电路板上的电子零件 (不包括特定电子零件), 内部相关连接线	X	0	0	0	0	0
框体	外壳, 面板, 背板等	X	0	0	0	0	0
特定电子零部件	变压器, 保险丝, 大型电解电容, 电源插座	X	0	0	0	0	0
附件	电线, 说明书, 包装等	X	0	0	0	0	0

本表格依据SJ/T 11364的规定编制

O: 表示该有害物质在该部件所有均质材料中的含量均在GB/T 26572 规定的限量要求以下。

X: 表示该有害物质至少在该部件的某一均质材料中的含量超出GB/T 26572规定的限量要求。



在中华人民共和国境内销售的电子电气产品上将印有“环保使用期”(EPuP)符号。圆圈中的数字代表产品的正常环保使用年限。



HARMAN International Industries, Inc.
8500 Balboa Boulevard, Northridge, CA 91329 USA

© 2020 HARMAN International Industries, Incorporated. All rights reserved.
JBL and HDI (High Definition Imaging) are trademarks of HARMAN International Industries, Incorporated, registered in the United States and/or other countries.
PolyPlas and Symmetrical Field Geometry are trademarks of HARMAN International Industries, Incorporated.
Features, specifications and appearance are subject to change without notice.
www.jblsynthesis.com

Part No. 950-0564-001